

LUBRICANT	INTERVAL	AMOUNT
Mobilgear 627 (ISO VG100) or equivalent	Initial: After 100 hours Subsequent: 2,000 hours or every 6 months under normal operating conditions NOTE: Clean magnetic drain plugs with each oil change.	½ Sight Glass

LUBRICATION:

All gearboxes are shipped lubricated. Ensure that lubrication has not leaked during shipping. If there are indications that lubrication has leaked:

Contact NIRECO America Corporation (845-856-4053) **IMMEDIATELY**. Do not mount and use gearbox until contacting manufacturer.

After the initial 100 hours of operation drain out initial oil, flush out the gearbox with an approved non-flammable, non-toxic solvent and refill. Thereafter, oil should be changed every 2,000 operating hours or every six months, whichever comes first. If gearbox is operating in extremely dirty or high or low temperature environment, change oil more often.

Lubrication procedure:

1. Remove a breather or pipe plug that is located above the sight glass level.
2. Remove the lowest drain pipe plug.
3. Let all of the lubrication drain into a container.
4. Remove all of the *magnetic* drain plugs. These plugs are all silver colored.
5. Clean all of the magnetic drain plugs.
6. Inspect the drained fluid for metal particles or other signs of excessive wear. If excessive wear is found, contact the manufacturer before replacing the gearbox.
7. Replace all of the pipe plugs below the sight glass.
8. Add oil until the level is one-half (½) of the sight glass.

Note: Vertical auxiliary shaft is permanent grease lubricated and sealed.

INSTALLATION:

Because of varying requirements, mounting hardware is not supplied with units. Good quality cap screws with lock washers should always be used. Base and fasteners for gearboxes must be rigid enough to maintain alignment.

Venting –Included with each gearbox is a vent kit. It is advisable to install the vent in place of one pipe plug above the fluid level in a convenient location.

Alignment – When installing care should be taken to align input and output shafts vertically and horizontally with connecting shafts. A flat and even mounting surface will help prevent uneven base hole bolt pressures. Flexible couplings will help compensate for minor variations in shaft alignment.

Couplings – Flexible couplings to pinion and cross shafts are recommended because they minimize bearing and gear wear caused by slight misalignment. Follow coupling and manufacturer’s installation directions.

Sheaves and sprockets - When mounting sheaves or sprockets, the center of the load should be located as close to the gearbox as possible. Excessive overhung loading could result in early failure of bearings. Refer to the general catalog or contact your local distributor for overhung load.

PREVENTATIVE MAINTENANCE:

Keep shafts and vent plug clean to prevent foreign particles from entering seals or gear case. Inspect periodically for oil leaks. Check couplings, setscrews and gearbox bolts for tightness (loose fasteners can cause alignment problems and excessive wear). Check endplay in shafts. Noticeable movement might indicate service or parts replacement.

PART ORDERING INFORMATION: When ordering parts, please provide model and serial number located on the gearbox nameplate along with item number and description of parts.

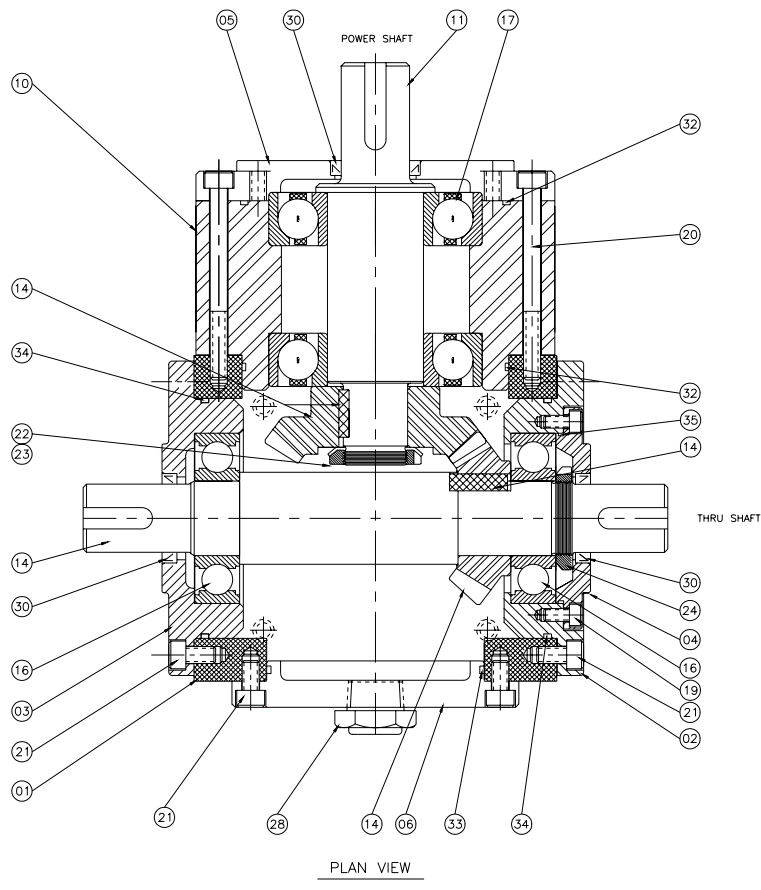

ITEM	QTY.	DESCRIPTION	ITEM	QTY.	DESCRIPTION
01	01	CASE	20	06	SCREW
02	01	BEARING CAP	21	08	SCREW
03	01	BEARING CAP	22	01	BEARING NUT
04	02	COVER: BEARING	23	01	BEARING NUT WASHER
05	01	COVER: HOUSING	24	02	BEARING NUTS
06	01	COVER: BACK	28	01	GAUGE
10	01	HOUSING: POW.SHAFT	30	04	SEAL
11	01	SHAFT: POWER	32	03	O-RING
14	01	GEARSET & SHAFT	33	02	O-RING
16	02	BEARING	34	02	O-RING
17	02	BEARING	35	02	O-RING
19	08	SCREW			

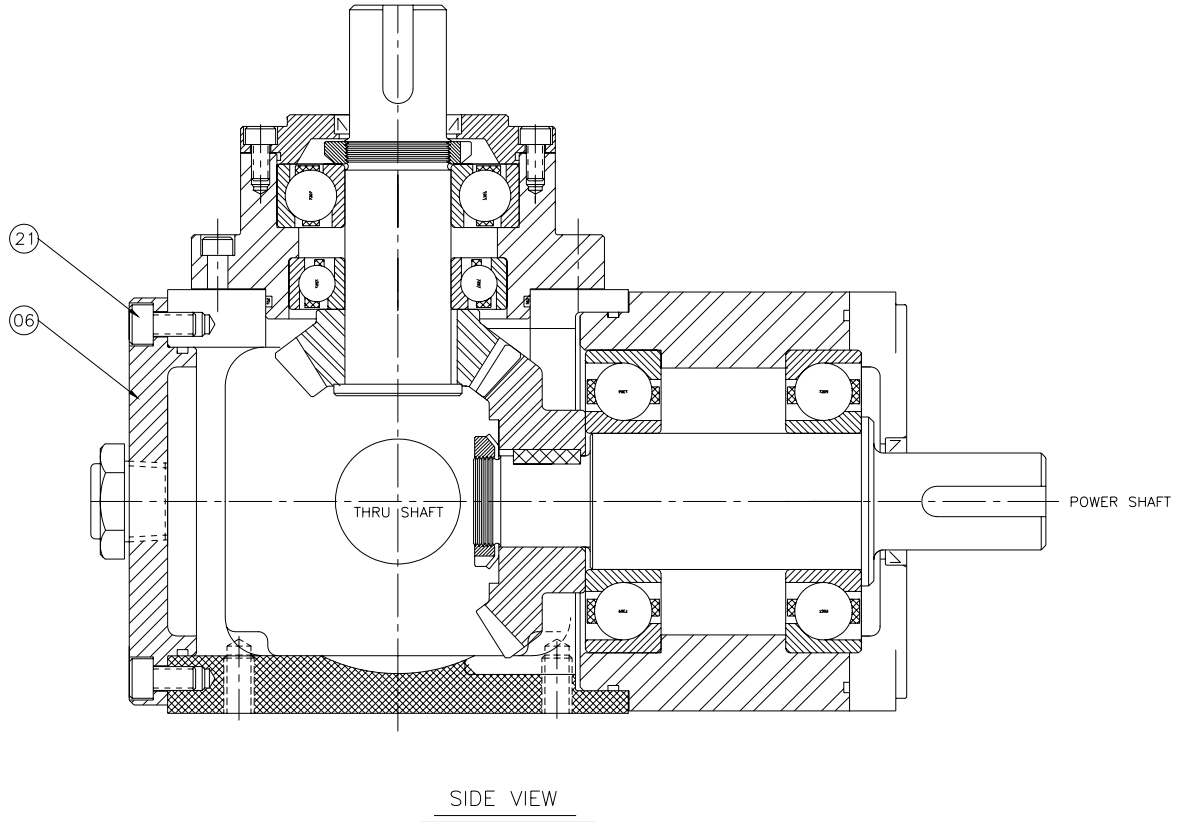

ITEM	QTY.	DESCRIPTION	ITEM	QTY.	DESCRIPTION
21	08	SCREW	06	01	COVER: BACK

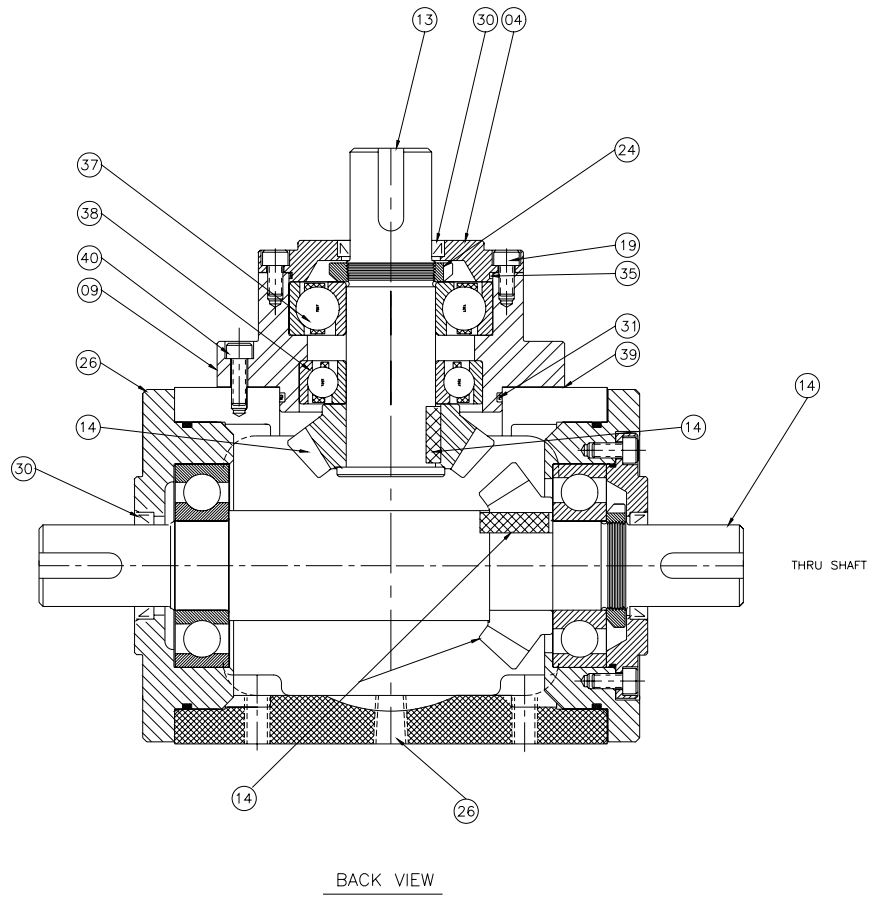

ITEM	QTY.	DESCRIPTION	ITEM	QTY.	DESCRIPTION
04	02	COVER: BEARING	30	04	SEAL
09	01	HOUSING: AUXOUT	31	02	O-RING
13	01	SHAFT: AUX. OUT	35	02	O-RING
14	01	GEARSET & SHAFT	37	01	BEARING
19	08	SCREW	38	01	BEARING
24	02	BEARING NUT	39	01	SHIM
26	01	PLUG	40	04	SCREW